

### FEATURES

- Complete rate gyroscope on a single chip
- Z-axis (yaw rate) response
- High vibration rejection over wide frequency
- 2000 g powered shock operation
- Self-test on digital command
- Temperature sensor output
- Precision voltage reference output
- Absolute rate output for precision applications
- 5 V single-supply operation
- Ultra small and light (< 0.15 cc, < 0.5 gram)

### APPLICATIONS

- Vehicle chassis rollover sensing
- Inertial measurement units
- Platform stabilization

### GENERAL DESCRIPTION

The ADXRS300 is a complete angular rate sensor (gyroscope) that uses Analog Devices' surface-micromachining process to make a functionally complete and low cost angular rate sensor integrated with all of the required electronics on one chip. The manufacturing technique for this device is the same high volume BIMOS process used for high reliability automotive airbag accelerometers.

The output signal, RATEOUT (1B, 2A), is a voltage proportional to angular rate about the axis normal to the top surface of the package (see Figure 2). A single external resistor can be used to lower the scale factor. An external capacitor is used to set the bandwidth. Other external capacitors are required for operation (see Figure 3).

A precision reference and a temperature output are also provided for compensation techniques. Two digital self-test inputs electromechanically excite the sensor to test proper operation of both sensors and the signal conditioning circuits.

The ADXRS300 is available in a 7 mm × 7 mm × 3 mm BGA surface-mount package.

### FUNCTIONAL BLOCK DIAGRAM

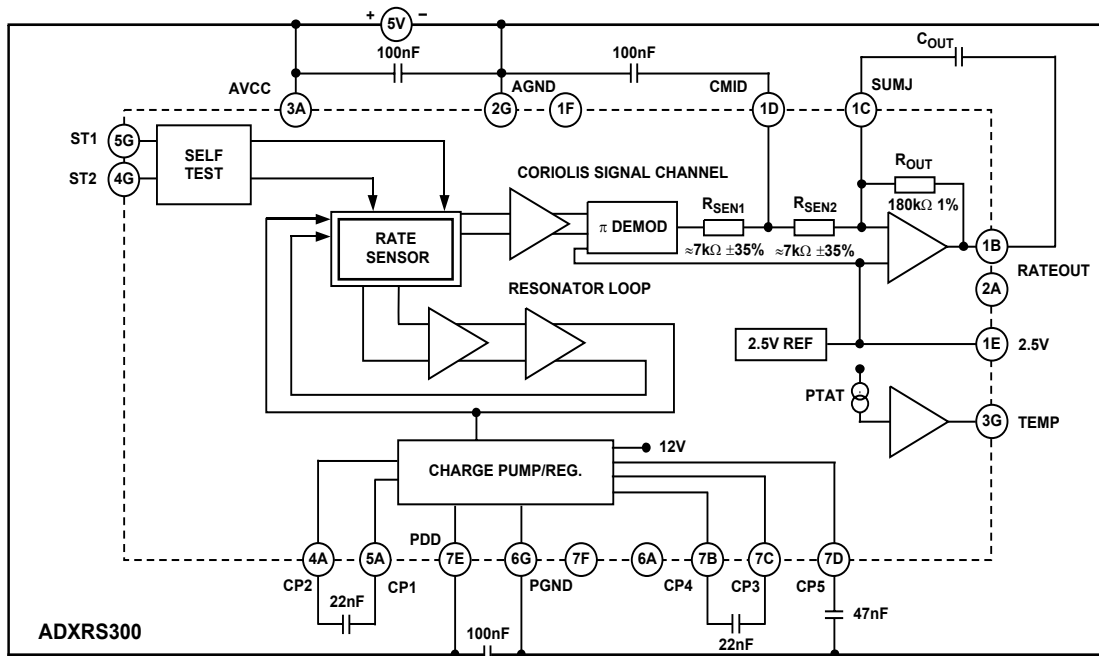

Figure 1

### Rev. 0

Information furnished by Analog Devices is believed to be accurate and reliable. However, no responsibility is assumed by Analog Devices for its use, nor for any infringements of patents or other rights of third parties that may result from its use. Specifications subject to change without notice. No license is granted by implication or otherwise under any patent or patent rights of Analog Devices. Trademarks and registered trademarks are the property of their respective companies.

# ADXRS300

## TABLE OF CONTENTS

ADXRS300—Specifications .....	3	Null Adjust.....	6
Absolute Maximum Ratings .....	4	Self-Test Function.....	6
Rate Sensitive Axis .....	4	Continuous Self-Test.....	6
Theory of Operation .....	5	Pin Configuration and Pin Function Descriptions.....	7
Supply and Common Considerations .....	5	Outline Dimensions .....	8
Setting Bandwidth.....	5	Ordering Guide.....	8
Increasing Measurement Range.....	6		
Using the ADXRS300 with a Supply-Ratiometric ADC.....	6		

## REVISION HISTORY

Revision 0: Initial Version

## ADXRS300—SPECIFICATIONS

@T<sub>A</sub> = 25°C, V<sub>S</sub> = 5 V, Angular Rate = 0°/s, Bandwidth = 80 Hz (C<sub>OUT</sub> = 0.01 μF), Unless Otherwise Noted.

Parameter	Conditions	ADXRS300ABG			Unit	
		Min <sup>1</sup>	Typ	Max <sup>1</sup>		
SENSITIVITY	Clockwise Rotation Is Positive Output					
	Dynamic Range <sup>2</sup>	Full-Scale Range over Specifications Range			°/s	
	Initial	@25°C	4.6	5	5.4	mV/°/s
	Over Temperature <sup>3</sup>	V <sub>S</sub> = 4.75 V to 5.25 V	4.6	5	5.4	mV/°/s
NULL	Nonlinearity	Best Fit Straight Line			% of FS	
	Initial Null		2.3	2.50	2.7	V
	Over Temperature <sup>3</sup>	V <sub>S</sub> = 4.75 V to 5.25 V	2.3		2.7	V
	Turn-On Time	Power on to ±½°/s of Final		35		ms
	Linear Acceleration Effect	Any Axis		0.2		°/s/g
NOISE PERFORMANCE	Voltage Sensitivity	V <sub>CC</sub> = 4.75 V to 5.25 V		1		°/s/V
	Rate Noise Density	@25°C		0.1		°/s/√Hz
FREQUENCY RESPONSE	3 dB Bandwidth (User Selectable) <sup>4</sup>	22 nF as Comp Cap (see Applications Section)		40		Hz
	Sensor Resonant Frequency			14		kHz
SELF-TEST INPUTS	ST1 RATEOUT Response <sup>5</sup>	ST1 Pin from Logic "0" to "1"	-150	-270	-450	mV
	ST2 RATEOUT Response <sup>5</sup>	ST2 Pin from Logic "0" to "1"	+150	+270	+450	mV
	Logic "1" Input Voltage	Standard High Logic Level Definition	3.3			V
	Logic "0" Input Voltage	Standard Low Logic Level Definition			1.7	V
	Input Impedance	To Common		50		kΩ
TEMPERATURE SENSOR	V <sub>OUT</sub> at 298°K			2.50		V
	Max Current Load on Pin	Source to Common			50	μA
	Scale Factor	Proportional to Absolute Temperature		8.4		mV/°K
OUTPUT DRIVE CAPABILITY	Output Voltage Swing	I <sub>OUT</sub> = ±100 μA	0.25		V <sub>S</sub> - 0.25	V
	Capacitive Load Drive		1000			pF
2.5 V REFERENCE	Voltage Value		2.45	2.5	2.55	V
	Load Drive to Ground	Source		200		μA
	Load Regulation	0 < I <sub>OUT</sub> < 200 μA		5.0		mV/mA
	Power Supply Rejection	4.75 V <sub>S</sub> to 5.25 V <sub>S</sub>		1.0		mV/V
	Temperature Drift	Delta from 25°C		5.0		mV
POWER SUPPLY	Operating Voltage Range		4.75	5.00	5.25	V
	Quiescent Supply Current			6.0	8.0	mA
TEMPERATURE RANGE	Specified Performance Grade A	Temperature Tested to Max and Min Specs.	-40		+85	°C

Table 1

1 All min and max specifications are guaranteed. Typical specifications are not tested or guaranteed.

2 Dynamic range is the maximum full-scale measurement range possible, including output swing range, initial offset, sensitivity, offset drift, and sensitivity drift at 5 V supplies.

3 Specification refers to the maximum extent of this parameter as a worst-case value at T<sub>MIN</sub> or T<sub>MAX</sub>.

4 Frequency at which response is 3 dB down from dc response with specified compensation capacitor value. Internal pole forming resistor is 180 kΩ. See Setting Bandwidth section.

5 Self-test response varies with temperature. Refer to the Self-Test Function section for details.

## ABSOLUTE MAXIMUM RATINGS

Parameter	Rating
Acceleration (Any Axis, Unpowered, 0.5 ms)	2000 g
Acceleration (Any Axis, Powered, 0.5 ms)	2000 g
+V <sub>s</sub>	-0.3 V to +6.0 V
Output Short-Circuit Duration (Any Pin to Common)	Indefinite
Operating Temperature Range	-55°C to +125°C
Storage Temperature	-65°C to +150°C

Table 2

Stresses above those listed under the Absolute Maximum Ratings may cause permanent damage to the device. This is a stress rating only; functional operation of the device at these or any other conditions above those indicated in the operational section of this specification is not implied. Exposure to absolute maximum rating conditions for extended periods may affect device reliability.

Applications requiring more than 200 cycles to MIL-STD-883 Method 1010 Condition B (-55°C to +125°C) require underfill or other means to achieve this requirement.

Drops onto hard surfaces can cause shocks of greater than 2000 g and exceed the absolute maximum rating of the device. Care should be exercised in handling to avoid damage.

## Rate Sensitive Axis

This is a Z-axis rate-sensing device that is also called a yaw-rate sensing device. It produces a positive going output voltage for clockwise rotation about the axis normal to the package top, i.e., clockwise when looking down at the package lid.

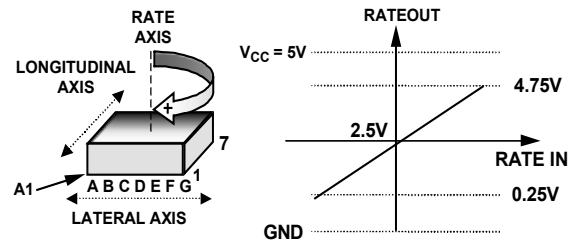

Figure 2. RATEOUT Signal Increases with Clockwise Rotation



# ADXRS300

between the RATEOUT (1B, 2A) and SUMJ (1C, 2C) pins will result in:

$$R_{OUT} = (180\text{ k}\Omega \times R_{EXT}) / (180\text{ k}\Omega + R_{EXT})$$

The -3 dB frequency is set by RSEN (the parallel combination of R<sub>SEN1</sub> and R<sub>SEN2</sub>) at about 3.5 kΩ nominal, and CMID is less well controlled since R<sub>SEN1</sub> and R<sub>SEN2</sub> have been used to trim the rate sensitivity during manufacturing and have a ±35% tolerance. Its primary purpose is to limit the high frequency demodulation artifacts from saturating the final amplifier stage. Thus, this pole of nominally 400 Hz @ 0.1 μF need not be precise. Lower frequency is preferable, but its variability usually requires it to be about 10 times greater (in order to preserve phase integrity) than the well-controlled output pole. In general, both -3 dB filter frequencies should be set as low as possible to reduce the amplitude of these high frequency artifacts as well as to reduce the overall system noise.

## Increasing Measurement Range

The full-scale measurement range of the ADXRS300 can be increased by placing an external resistor between the RATEOUT (1B, 2A) and SUMJ (1C, 2C) pins, which would parallel the internal R<sub>OUT</sub> resistor that is factory-trimmed to 180 kΩ. For example, a 330 kΩ external resistor will give ~50% increase in the full-scale range. This is effective for up to a 4× increase in the full-scale range (minimum value of the parallel resistor allowed is 45 kΩ). Beyond this amount of external sensitivity reduction, the internal circuitry headroom requirements prevent further increase in the linear full-scale output range. The drawbacks of modifying the full-scale range are the additional output null drift (as much as 2°/sec over temperature) and the readjustment of the initial null bias (see the Null Adjust section).

## Using the ADXRS300 with a Supply-Ratiometric ADC

The ADXRS300's RATEOUT signal is nonratiometric, i.e., neither the null voltage nor the rate sensitivity is proportional to the supply. Rather they are nominally constant for dc supply changes within the 4.75 V to 5.25 V operating range. If the ADXRS300 is used with a supply-ratiometric ADC, the ADXRS300's 2.5 V output can be converted and used to make corrections in software for the supply variations.

## Null Adjust

Null adjustment is possible by injecting a suitable current to SUMJ (1C, 2C). Adding a suitable resistor to either ground or the positive supply is a simple way of achieving this. The nominal 2.5 V null is for a symmetrical swing range at RATEOUT (1B, 2A). However, a nonsymmetrical output swing may be suitable in some applications. Note that if a resistor is connected to the positive supply, then supply disturbances may reflect some null instabilities. Digital supply noise should be avoided particularly in this case (see the Supply and Common Considerations section).

The resistor value to use is approximately:

$$R_{NULL} = (2.5 \times 180,000) / (V_{NULL0} - V_{NULL1})$$

V<sub>NULL0</sub> is the unadjusted zero rate output, and V<sub>NULL1</sub> is the target null value. If the initial value is below the desired value, the resistor should terminate on common or ground. If it is above the desired value, the resistor should terminate on the 5 V supply. Values typically are in the 1 MΩ to 5 MΩ range.

If an external resistor is used across RATEOUT and SUMJ, then the parallel equivalent value is substituted into the above equation. Note that the resistor value is an estimate since it assumes V<sub>CC</sub> = 5.0 V and V<sub>SUMJ</sub> = 2.5 V.

## Self-Test Function

The ADXRS300 includes a self-test feature that actuates each of the sensing structures and associated electronics in the same identical manner as if subjected to angular rate. It is activated by standard logic high levels applied to inputs ST1 (5F, 5G), ST2 (4F, 4G), or both. ST1 will cause a voltage at RATEOUT equivalent to typically -270 mV and ST2 will cause an opposite +270 mV change. The self-test response follows the viscosity temperature dependence of the package atmosphere, approximately 0.25%/°C.

Activating both ST1 and ST2 simultaneously is not damaging. Since ST1 and ST2 are not necessarily closely matched, actuating both simultaneously may result in an apparent null bias shift.

## Continuous Self-Test

The one-chip integration of the ADXRS300 gives it higher reliability than is obtainable with any other high volume manufacturing method. Also, it is manufactured under a mature BIMOS process that has field-proven reliability. As an additional failure detection measure, power-on self-test can be performed. However, some applications may warrant continuous self-test while sensing rate. Application notes outlining continuous self-test techniques are also available on the Analog Devices website.

## PIN CONFIGURATION AND PIN FUNCTION DESCRIPTIONS

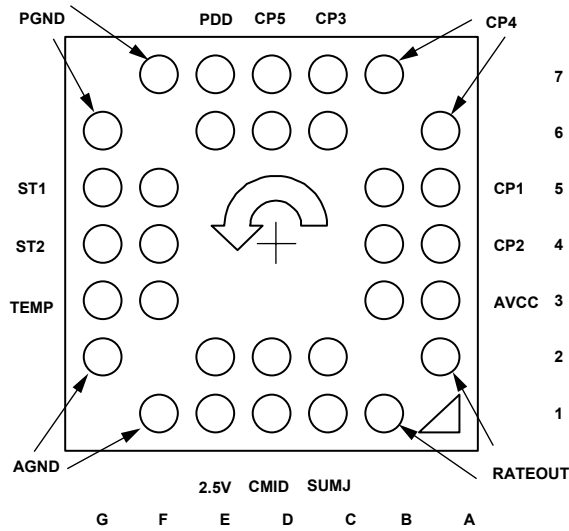

Figure 5. BGA-32 (Bottom View)

### 32-LEAD BGA

Pin No.	Mnemonic	Description
6D, 7D	CP5	HV Filter Capacitor—47 nF
6A, 7B	CP4	Charge Pump Capacitor—22 nF
6C, 7C	CP3	
5A, 5B	CP1	Charge Pump Capacitor—22 nF
4A, 4B	CP2	
3A, 3B	AVCC	+ Analog Supply
1B, 2A	RATEOUT	Rate Signal Output
1C, 2C	SUMJ	Output Amp Summing Junction
1D, 2D	CMID	HF Filter Capacitor—100 nF
1E, 2E	2.5V	2.5 V Precision Reference
1F, 2G	AGND	Analog Supply Return
3F, 3G	TEMP	Temperature Voltage Output
4F, 4G	ST2	Self-Test for Sensor 2
5F, 5G	ST1	Self-Test for Sensor 1
6G, 7F	PGND	Charge Pump Supply Return
6E, 7E	PDD	+ Charge Pump Supply

Table 3: Pin Function Descriptions—32-Lead BGA

# ADXRS300

## OUTLINE DIMENSIONS

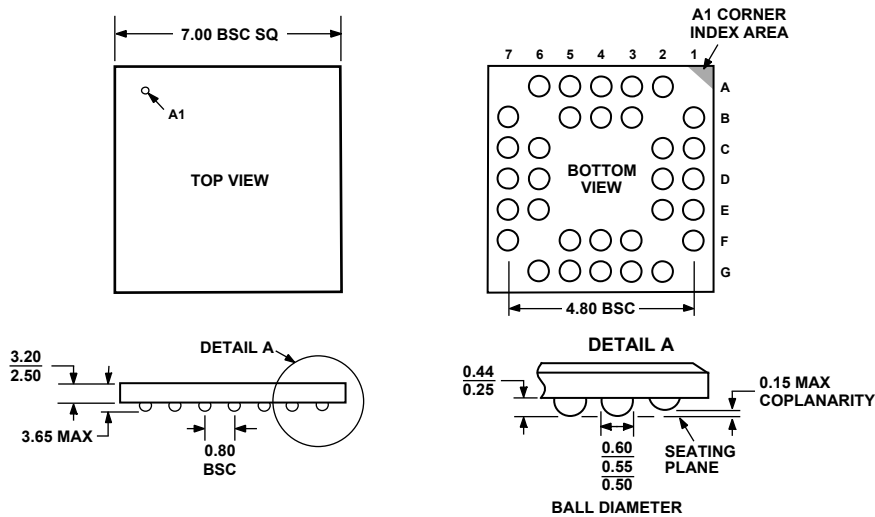

Figure 6. 32-Lead Chip Scale Ball Grid Array [CSPBGA]  
(BC-32)  
Dimensions shown in millimeters

### ESD CAUTION

ESD (electrostatic discharge) sensitive device. Electrostatic charges as high as 4000 V readily accumulate on the human body and test equipment and can discharge without detection. Although this product features proprietary ESD protection circuitry, permanent damage may occur on devices subjected to high energy electrostatic discharges. Therefore, proper ESD precautions are recommended to avoid performance degradation or loss of functionality.



### Ordering Guide

ADXRS300 Products	Temperature Package	Package Description	Package Outline
ADXRS300ABG	-40°C to +85°C	32-Lead BGA	BC-32
ADXRS300ABG-Reel	-40°C to +85°C	32-Lead BGA	BC-32

Table 4



This datasheet has been download from:

[www.datasheetcatalog.com](http://www.datasheetcatalog.com)

Datasheets for electronics components.